

7900070918

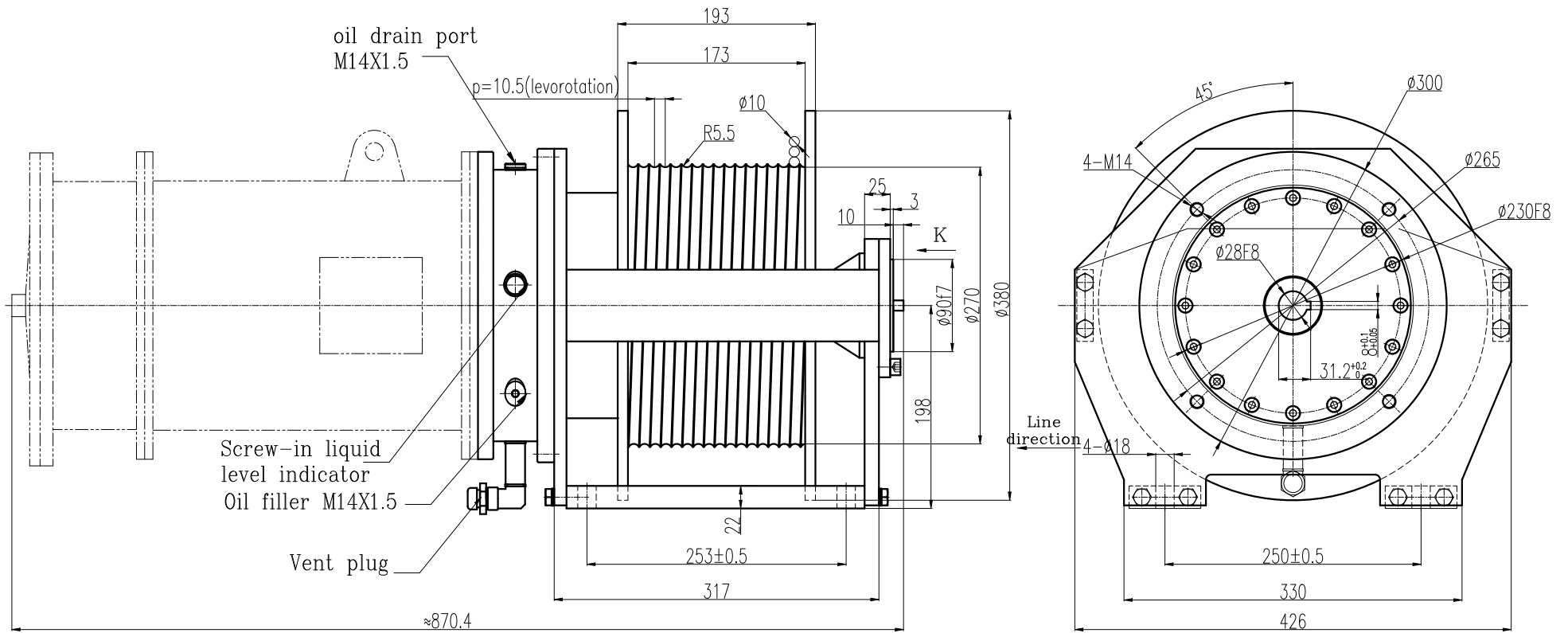

借通用件登记

Technical parameters of winch

First layer tension (KN)	10
Average rope speed (m/min)	8
Rope diameter (mm)	10
Number of rope layers (layers)	3
Rope capacity of drum (m)	35(including 3 safety turns)
Motor type	YZ112M-6-H-B5(customer-owned)
Voltage (V)	440
Frequency (Hz)	60
Motor speed (rpm)	1068
Power (Kw)	1.8
Velocity ratio	122

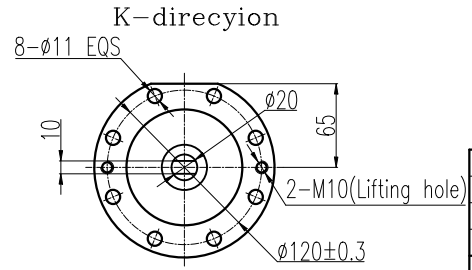

mark number	changed file number	signature	date	FDJ07-10-35-10-YZ112M			Ningbo Flag-up Hydraulic 1 ton electric winch
designer	inspector	approver		pattern mark	weight	proportion	
craft						1:4	816040006L
standard		date	2022/12/14	version	visual angle	$\square \oplus$	