

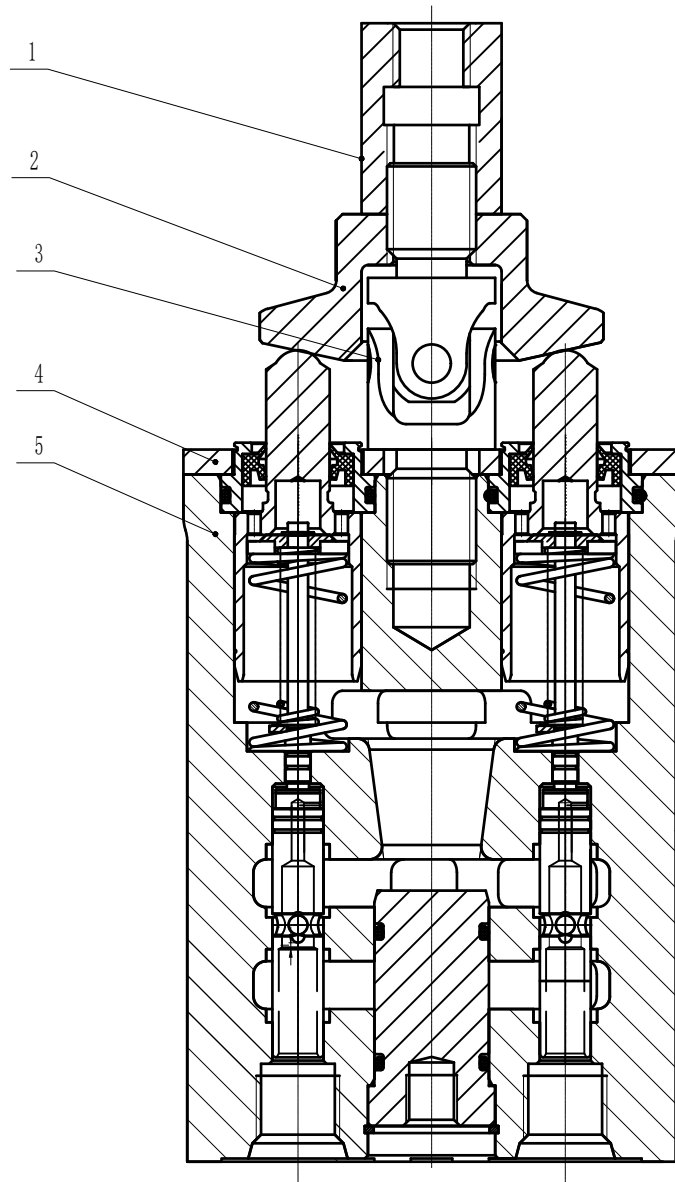

810900122

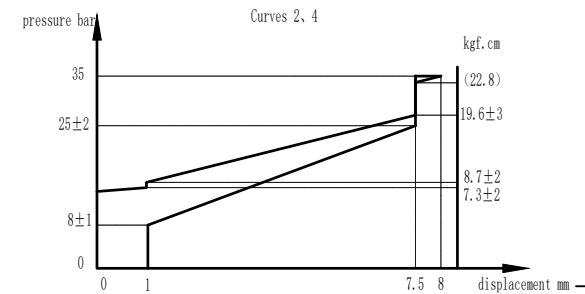

- Technical requirements:
1. Maximum pressure: 100 bar
 2. Rated pressure: 35 bar
 3. rated flow: 15 L/min
 4. T mouth back pressure: 3 bar
 5. Use oil: mineral oil
 6. viscosity range: 10 ~ 380 mm²/s
 7. oil temperature: -20°C ~ 80°C
 8. Cleanliness: NAS Level 9

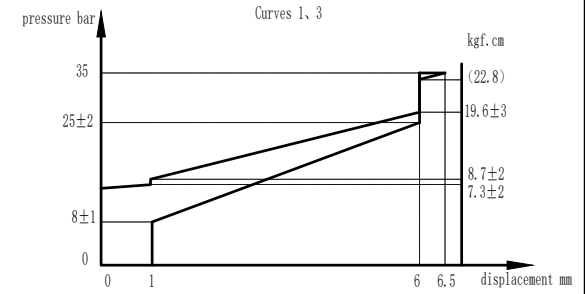

5	110900078	valve body components	1				
4	300700133	fixed plate	1	Q235A			
3	700900001	universal joint	1				
2	300800145	rocking seat	1	ZG40Cr			
1	300900022	Adjusting nut	1	Hexagonal steel S=19			
serial number	code name	name	quantity	material	signal weight	total weight	remark

				FPJ-F9-X0			 Ningbo Flag-up Hydraulic flag-up	
				assembly drawing				
				810900122				
mark number	changed file number	signature	date	designer	approver	pattern mark	weight	proportion
								1:1.2
standard		date		version		visual angle	